

NEWS

To Report on Philadelphia

Since the Philadelphia fall meeting will be held October 10-12, approximating the publication date of the October issue of the Journal, coverage will be scheduled for the November issue, with a follow-up in the December issue if necessary. P. E. Ronzone is general chairman of the meeting, and W. C. Ault, program chairman. A total of 56 papers is to be presented.

Appoints New Subcommittee

A subcommittee of the Seed and Meal Analysis Committee, of which T. H. Hopper is chairman, has been named by the president of the American Oil Chemists' Society, W. A. Peterson. It will be known as the subcommittee for the determination of urease in soybean meal. T. H. Potts of Ralston Purina Company, St. Louis, will be chairman, and others are: M. W. Dippold, Spencer Kellogg and Sons Inc., Decatur, Ill.; K. E. Holt, Archer-Daniels-Midland Company, Minneapolis, Minn.; G. H. Kyser, General Mills Inc., Belmond, Ia.; V. C. Mehlenbacher, Swift and Company, Chicago, Ill.; and J. S. Baker, Procter and Gamble Company, Cincinnati, O.

N. C. Hill Dies

Norman C. Hill of the C. P. Hall Company, Akron, O., died on August 12, 1955. He had become a member of the American Oil Chemists' Society in 1954.

Apology

BECAUSE of the fact that it was not possible to get all of the 1955 short course papers into type and proof-read in time for the October issue, the choice lay between publishing part of the papers in this issue or in delaying publication until the November issue. The latter course was chosen, and the supplement on Analytical Techniques will therefore appear in the November 1955 issue. Bound reprints will be available later. Selling price for issue and reprint will be \$3 each.

EDITOR, THE JOURNAL.

Offer Booklet on Skin Diseases

THE Association of American Soap and Glycerine Producers Inc., has recently published a 42-page booklet entitled "The Prevention of Occupational Skin Diseases," by Louis Schwartz, retired medical director of the U. S. Public Health Service. It is being supplied to industry by companies that produce and sell skin cleaners. Copies may also be purchased direct from the Association, 295 Madison avenue, New York 17, N. Y.

Bird Names Mexican Representative

BIRD MACHINERY COMPANY, South Walpole, Mass., has announced the appointment of Desarrollo Industrial, Beristain 47, Mexico, D. F., as exclusive representative in Mexico for all Bird-pressure leaf filter applications in the vegetable oil, fat, fatty acid, lard, and grease industries, and in rendering plants. Technical assistance on Bird pressure filter applications will be supplied by A. Gonzalez Flores, who has erected and installed numerous oil filtration plants in Mexico.

This BIRD Pressure Filter Is Designed And Built For VEGETABLE OILS

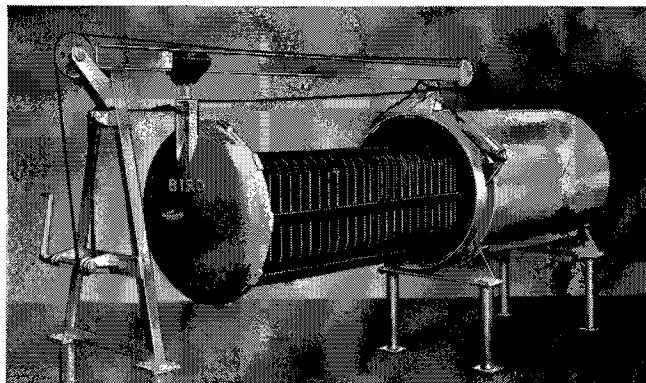

Experts who **know** the oil industry are prepared to furnish layouts and estimates on installations for

- filtration of vegetable oils
- filtration of stearins from winterized oils
- removal of bleaching clays
- polishing of solvent extraction oils
- recovering nickel catalyst from hydrogenated oils

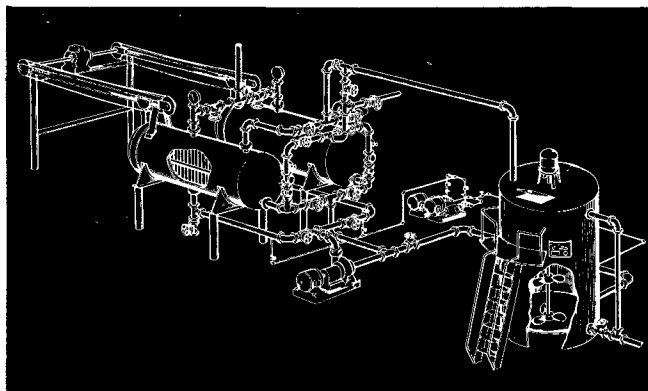

Here is a representative installation of two Bird Filters. Note that the filtrate discharge is at the fixed end of the tank. You don't have to disconnect piping every time the Filter is opened. Only the Bird's exclusive self-sealing filtrate manifold makes this possible.

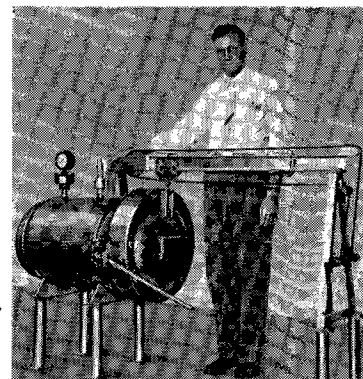

Pilot-size Bird Pressure Filters complete in every detail are available for accurate performance pre-testing.

Write for NEW BULLETIN giving complete information on the Bird Pressure Filter.

BIRD MACHINE COMPANY
South Walpole, Massachusetts
REGIONAL OFFICES: Evanston, Illinois; Portland, Oregon



WHITLEY COLLINS

Portrait by Fabian Bachrach

“Over 80% of Northrop personnel buy U.S. Savings Bonds . . .”

“Our recent Payroll Savings Campaign at Northrop demonstrated the belief of our personnel and our company in the basic fundamentals of American good citizenship—staunch support of our Country and personal thrift.

“At the completion of the campaign we had over 17,000 regular savers—over 80% of all Northrop personnel buying U. S. Savings Bonds regularly on the

Payroll Savings Plan. Every employer should stage a similar campaign for the benefit of his personnel and the economic welfare of our Country.”

WHITLEY COLLINS, President
Northrop Aircraft Company

If less than 60% of your personnel are Payroll Savers, do something about it. A phone call, telegram or letter to Savings Bonds Division, U. S. Treasury Department, Washington, D. C., will bring prompt assistance from your State Director. He will help you install, or revitalize a Payroll Savings Plan, through a simple, person-to-person canvass which your personnel will be glad to conduct. That's all you have to do—your men and women will do the rest.

The United States Government does not pay for this advertising. The Treasury Department thanks, for their patriotic donation, the Advertising Council and

JOURNAL OF THE AMERICAN OIL CHEMISTS' SOCIETY



New Members

Active

- Oran L. Bennett, chemist-in-charge, Meat Inspection Laboratory, U. S. D. A. Agriculture Research Service, Chicago, Ill.
- Llewellyn W. Burdette, section manager, Surfactants Development Section, General Aniline and Film Corporation, Linden, N. J.
- Hollis B. Copeland, assistant chief chemist, Wilson and Company, Chattanooga, Tenn.
- Robert Owen Crisler, chemist, Procter and Gamble Company, Cincinnati, O.
- Frank W. Dittman, process engineer, Rust Engineering Company, Pittsburgh, Pa.
- Jay Dean Etheridge, chemist, Best Foods Inc., Dallas, Tex.
- Frank J. Hawkins, chemist, Celina Stearic Acid Company, Celina, O.
- Ernest J. Jacobson, chemist, Pacific Vegetable Oil Corporation, Richmond, Calif.
- Louise David Long, sales, Arthur S. La Pine and Company, Chicago, Ill.
- Donald V. Magnuson, director of research, Labline Inc., Chicago, Ill.
- Charles F. Oberg, assistant chemist, Product Control Laboratory, Oscar Mayer and Company, Madison, Wis.
- Carlos Ortega, chief chemist, Industrias Gonzalez S. A., Monterrey, N. L., Mexico
- David I. Quinlan, partner-plant manager, Seaboard Chemicals Inc., Beverly, Mass.
- Milton J. Rosen, chemical consultant, Department of Chemistry, Brooklyn College, Brooklyn, N. Y.
- Maurice A. Rust, director, Industrial Laboratories Company Inc., Denver, Colo.
- Frank A. Schlachter, chemist, Armour and Company, Chicago, Ill.
- Robert H. Sifferd, special projects coordinator, Armour Laboratories, Kankakee, Ill.
- Otto W. Wechmann, chemist, Harburger Oelwerke Brinckman and Mergell, Hamburg, Germany
- Robert L. Wille, chemical engineer, Procter and Gamble Company, Cincinnati, O.

Individual Associate

- John Dee Martin, laboratory supervisor, Western Cottonoil Company, Lubbock, Tex.

Corporation Associate

- Curry and Paxton Inc., representative, Hayes G. Shimp Jr., New York, N. Y.

New Literature

The chemical plants division of Blaw-Knox Company, Pittsburgh, Pa., is offering a new series of descriptive and technical data in engineering, construction, and initial operation of plants. The scope and purpose of the series, known as the Chemical Plants Reference File, is outlined in file 1-1.1.

A new semi-automatic electrical needle and pipette puller is described in Section F, Sheet 1, from C. A. Brinkmann and Company, Great Neck, L. I., N. Y.

The United States Testing Company, Hoboken, N. J., has published a new 112-page booklet entitled "Selected Scientific and Engineering Tables and Data" in commemoration of the company's 75th anniversary.

On the Educational Front

Columbia University has been given a grant-in-aid by the Heyden Chemical Corporation, New York, N. Y., for organic chemical research under the direction of Cheves Walling, professor of chemistry. The studies, concerned with the effect of structure on reactivity in aromatic halogenation, will be carried out by Burton B. Jacknow.

Ethyl Corporation, New York, N. Y., has awarded 19 graduate research fellowships, totalling about \$45,000, in the fields of chemistry, chemical engineering, and mechanical engineering for the 1955-56 academic year. Ethyl Corporation has awarded fellowships annually since 1937.

Thomas D. O'Brien has been named as head of the department of chemistry at Kansas State College, Manhattan, Kans. He will also serve as chemist in charge of the Kansas Agricultural Experiment Station.

Commission Internationale des Industries Agricoles

International Commission for Agricultural and Food Industries

SCIENTIFIC AND TECHNICAL RESEARCH INFORMATION DOCUMENTATION

concerning all questions of breeding-plants, especially fruits, for industrial utilization—biological, agricultural, and food industries.

Subscribe to our reviews:

Industries Agricoles et Alimentaires
Revue Internationale des Industries Agricoles
Annales des Falsifications et des Fraudes.

Use our services:

Laboratories — Documentation Center — Patent Service — Bibliographic Studies — Translations — Technical and Economical Information — Catalogues — Photoduplication-Services (Microfilms and Photostats).

Write for specimen to our agencies:

18 Avenue de Villars, Paris VII^e, France
38 Boulevard du Régent, Bruxelles, Belgium
51 Route de Frontenex, Genève, Switzerland
c/o Dr. Fellner, 416 Fifth St. N.W., Washington, D. C.



» Fette • Seifen • Anstrichmittel «

Editor: Prof. Dr. H. P. Kaufmann

is the leading scientific journal in the field of fats and fat products as well as their associated products in Germany. It is the organ of Der Deutschen Gesellschaft für Fettwissenschaft (DGF).

Subscription rates are
U. S. \$15 a Year

Anyone interested in exchanging back issues of Oil & Soap or the Journal of the American Oil Chemists' Society for Fette und Seifen should write to Industrieverlag von Hernhausen K. G., Rodingsmarkt 24, Hamburg 11, Germany.

WHATMAN

Filter Papers for

CHROMATOGRAPHY

The literature of Chromatography Electrophoresis and related methods of analysis is full of references to WHATMAN Filter Papers.

Your dealer in laboratory supplies carries a selection of circles, sheets, rolls and strips for paper chromatography and electrophoresis as well as WHATMAN Cellulose Powders for column work.

Should you require special sizes or shapes or desire technical information, please write direct to us.

H. REEVE ANGEL & CO. Inc.

52 Duane St. New York 7, N. Y.

WHATMAN and Reeve Angel Filter Papers are recommended for many A.O.C.S. Analyses

WHATMAN
HIGH GRADE FILTER PAPERS

New Books

A SHORT TEXTBOOK OF COLLOID CHEMISTRY, by B. Jirgensons and M. E. Straumanis (John Wiley and Sons Inc., New York; Pergamon Press Ltd., London, 1954, 420 pp., \$8). This is a completely revised version of the authors' "Kurzes Lehrbuch der Kolloidchemie", published in 1949. As stated in the preface, "This text is intended for students and research workers and for those interested in the branches of natural science . . . in which information about colloids is essential." This is an aim which the authors were quite successful in achieving.

This book is divided into two parts. The first part, consisting of three chapters, contains the definitions of fundamental terms, a brief historical review, and an outline of elementary laboratory methods used in work with colloids. This is intended for readers who wish to acquire an acquaintance with the nature of colloid chemistry. The second, and by far longer part, contains 16 chapters in which colloid chemistry is discussed in greater detail. This can be subdivided into four parts. First, there are five chapters on the kinetic properties of colloids, surface tension and adsorption phenomena, optical properties, electrical properties, and viscosity. These are followed by three chapters on the determination of the particle size, shape and structure by various physical techniques; then come three chapters on the preparation, coagulation, and stability of colloids, and finally five chapters on gels, emulsions, dispersions of gases, aerosols, and solid sols.

This book is clearly written, and the reader is greatly helped by the large number of excellent illustrations. Insofar as this book emphasizes experimental methods, it should prove quite valuable to the chemist who wishes to become introduced to the field of colloids and to the research worker desiring to gain a preliminary acquaintance with this rapidly growing field of science. The comprehensive coverage given by the authors is quite impressive when the compactness of the book is taken into consideration. For a reader interested in gaining a working knowledge of any of the described types of measurements, the authors have provided copious references to sources of detailed information. It is regrettable however that, in their effort to provide a broad survey of colloid science, the authors have tended towards oversimplification and have not emphasized the very serious complications which arise in the interpretation of data obtained with the methods of macromolecular chemistry and the necessity of gaining a thorough knowledge of the theories involved prior to the performance of actual measurements.

S. N. TIMASHEFF
Eastern Utilization Research Branch
Philadelphia, Pa.

POCKET BOOK OF CHEMICAL TECHNOLOGY, by V. Stannett and L. Mitlin (Chemical Publishing Company Inc.), 283 pp., 1954, \$4.75). As stated by the title, this is a pocketbook containing the information that is most frequently needed and used by chemical technologists. It is much less bulky than the handbooks with which we are more familiar. The contents of the book include the usual mathematical data, including four-place logarithms, conversion factors, properties of organic compounds, gravimetric factors, dissociation constants and buffer solutions, densities and specific gravities, which complete the physical data section.

In addition to the above, there is a chapter on fluid flow, heat transfer, distillation, materials of construction, some engineering data on pipes, flanges, and standard sections. There is also a section each on safety, first aid, common names of minerals, and a list of selected British Standards.

The mathematical data section of the book is presented in the usual form, giving mensurations, a few algebraic factors, and the more common logarithmic series. The section on trigonometry and the simple integrals is far from complete. The section on definitions of units and conversion factors is in a very usable form, and it is probably one of the most useful sections of the book.

The properties of the organic compounds cover about 10% of the book. In this section most of the more common organic materials are listed. The properties given are molecular weight, melting point, boiling point, density, refractive index, and qualitative solubility. There is nothing in the book under the properties of organic compounds to show the exact solubilities. The section on inorganic compounds is similar, covering about 14% of the book. These properties include color, melting point, boiling point, specific gravity, quantitative solubility in water, and qualitative solubility in other reagents. The section

devoted to gravimetric factors contains information found in most quantitative analysis textbooks.

The chapter on fluid flow includes the basic flow equations and four tables giving the viscosities of water, steam, the more common organic liquids, and common gases. The chapter on heat transfer presents the basic equations for heat transfer by conduction and radiation. Data on the thermal characteristics of commercial insulating materials, specific heats, over-all heat transfer coefficients, and heat losses is very limited or not given. In the chapter on distillation, vapor pressures of the common organic compounds are given as well as a table listing the more common azeotropic binary mixtures.

In the latter part of the book there are numerous tables giving properties of alloys and plastics. Also there is a section listing the common names of minerals and other substances, which is quite useful for identification purposes.

As previously stated, this book is a summary of the information usually presented in the more complete handbooks. It presents the fundamental data which might be useful to technical workers in the chemical fields who do not have a formal technical training. This book would not be a valuable addition to the library of a technically trained chemist or chemical engineer.

Because of its size this pocketbook of chemical data may have value as a readily available reference.

ROBERT J. FOSTER
General Mills Inc.
Minneapolis, Minn.

POLAROGRAPHIC TECHNIQUES, by Louis Meites (Interscience Publishers Inc., 317 pp. + xiii, 1955, \$6). This introductory text is printed with easily readable type on 6 x 9-in. pages. Both the paper and the binding are of very good quality. The nine chapters cover briefly the scope, instrumentation, techniques and theory of polarography. Appendix A contains pictures of polarograms produced by recording equipment which was defective or improperly adjusted. It provides a valuable diagnostic aid for the beginner. Appendix B contains an extensive tabulation of half-wave potentials and diffusion current constants for inorganic substances.

The objective of the text is to provide a concise, practical, and theoretical introduction into the field of polarography. In the opinion of this reviewer the author has succeeded very well in accomplishing this objective. However experienced workers in the field will find very little that is new to them in this book. The coverage of polarography of organic compounds is very limited. Applications to lipids are not mentioned. Since this is an introductory text, the author has chosen to omit literature references for the information given in the body of the text. However in the preface he calls the reader's attention to more comprehensive works, which give adequate references to the original literature. More than 300 literature citations are included for the half-wave potential and diffusion current values given in Appendix B.

This book is recommended to anyone contemplating work in polarography for the first time. It includes suggestions for the choice of equipment to be purchased for various applications. It is easy to read and comprehend since the author's presentation is logical and his style is direct. A person who reads this text carefully should be well oriented in the field of polarography and not likely to ignore important points of the theory or technique. However, it is likely that he will also wish to have access to a more comprehensive treatment such as Koltzoff and Lingane's "Polarography" for additional details on points which prove to be troublesome or especially important in his work.

WALTER R. LEWIS
Dept. of Agricultural Biochemistry
West Virginia University
Morgantown, W. Va.

1954 SUPPLEMENT TO BOOK OF A.S.T.M. STANDARDS INCLUDING TENTATIVES, Part 7, Textiles, Soap, Water, Paper, Adhesives, Shipping Containers (American Society for Testing Materials, 1916 Race street, Philadelphia, Pa., 275 pp., 1954, \$3.50 non-members, \$2.75 members). This paper-bound Supplement to the 1952 Book of ASTM Standards, Part 7, contains the new and revised standards and tentatives accepted since the

Only **FRENCH**
CAN SUPPLY ALL **3** IN
UNIVERSAL EXTRACTION PLANTS

Designed to fit existing facilities, French extractors are flexible in design and permit integral installation of preparation and extraction equipment with fire wall, or installation in separate areas.

If you are considering solvent extraction, it will pay you to investigate the French system that's flexible and truly universal for processing all types of oil seeds.

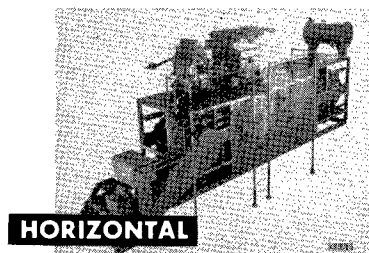

HORIZONTAL

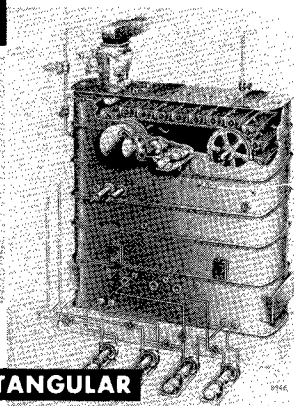

RECTANGULAR

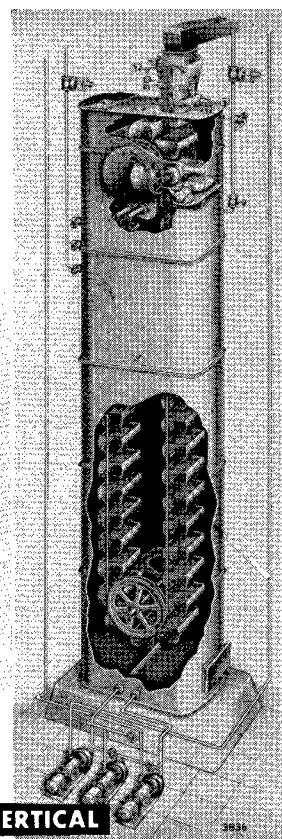

VERTICAL

DESIGNED FOR INDOOR OR OUTDOOR INSTALLATION

•MECHANICAL SCREW PRESSES •COOKER-DRYERS •SOLVENT EXTRACTION PLANTS •RENDERING MACHINERY •FLAKING AND CRUSHING ROLLS

THE FRENCH OIL MILL MACHINERY COMPANY
PIQUA, OHIO U. S. A.

B-C is BEST!

**Year In and Year Out
Day In and Day Out**

Most edible oil refiners have found this
statement true over the years

IF you want

- economical bleaching
- less FFA rise
- greater stability
- less filter cloth replacement
- better clay uniformity

*In other words
Better-Cheaper Bleaching*

USE B-C



BENNETT-CLARK CO., INC.

P. O. Box 951

NACOGDOCHES, TEXAS

appearance of the last Supplement in 1953. The 1953 and 1954 Supplements are essential parts of the 1952 Book of Standards.

The section on Soaps and Other Detergents contains the revised "Standard Methods of Sampling and Chemical Analysis of Alkaline Detergents," D501-54, the revised "Tentative Method of Test for pH of Aqueous Solutions of Soaps and Detergents," D1172-54T, and the new "Tentative Methods of Test for Surface and Interfacial Tension of Solutions of Surface Active Agents," D1331-54T. Yellow stickers are also provided to note minor revisions in "Methods of Sampling and Chemical Analysis of Soaps and Soap Products," D460-54, and in "Definitions of Terms Relating to Soaps and Other Detergents," D459-54.

LEMOYNE E. DECKER
Armour and Company
Soap Division
Chicago, Ill.

October — ABC Month, 1955

TO NEARLY EVERYONE in the world of advertising and publishing, October is ABC month. That's when most leading American and Canadian business publications, newspapers, and other periodicals show their circulation colors by displaying the symbol on page 2.

The Journal of the A.O.C.S. had to earn that symbol. Only publications which have qualified as members in good standing of the Audit Bureau of Circulations can display it. And to qualify, the Journal had to prove that its circulation met high standards of integrity, standards that imply responsibility to our readers and mean full measure of circulation value for our advertisers.

The ABC symbol is the advertiser's highest standard of circulation value. It means that we are pledged to keep true and correct circulation records and report our circulation with known and accepted rules.

This Hallmark of Circulation Value to advertisers is like the "sterling" mark on silver. Just as merchants and manufacturers buy and sell physical goods on the basis of known standards of grade, weight and measure, so do ABC publications, including the Journal, sell their advertising space on the foundation of ABC circulation standards.

The Audit Bureau of Circulations is a unique, non-profit association of 3,670 advertisers, advertising agencies, and publications. Through ABC, representatives of both buyer and seller members, meeting regularly to solve mutual problems about circulation, establish and maintain commonly-accepted definitions of net paid circulation. Buyer members have a majority voice in establishing these definitions and Bureau rules.

Then each year a member of ABC's 70-man field auditing staff calls. He personally audits our records, finds out whether or not our circulation meets industry standards, and sums up the solid numerical facts about our circulation value.

The auditor's findings are then published in ABC Reports—compilations of circulation facts and figures vital to every advertiser who wants to know what he's buying when he invests in advertising.

This system, possible only through an independent, responsible, buyer-and-seller maintained association like ABC, is a constant protection to the Journal, our advertisers, and our readers.

The primary objective of the work of the Audit Bureau of Circulations is to supply advertisers with accurate, verified information about the net paid circulation of all publisher members.

We are proud to be numbered among the publications which provide ABC audit reports as factual measures of advertising value.

A.O.C.S. CALENDAR

1955

Fall Meeting: Bellevue-Stratford Hotel, Oct. 10-12, Philadelphia

1956

Spring Meeting: Shamrock Hotel, Houston, Apr. 23-25
Fall Meeting: Sherman Hotel, Sept. 23-26, Chicago

1957

Spring: New Orleans; Fall: Cincinnati

1958

Spring: Memphis; Fall: Chicago

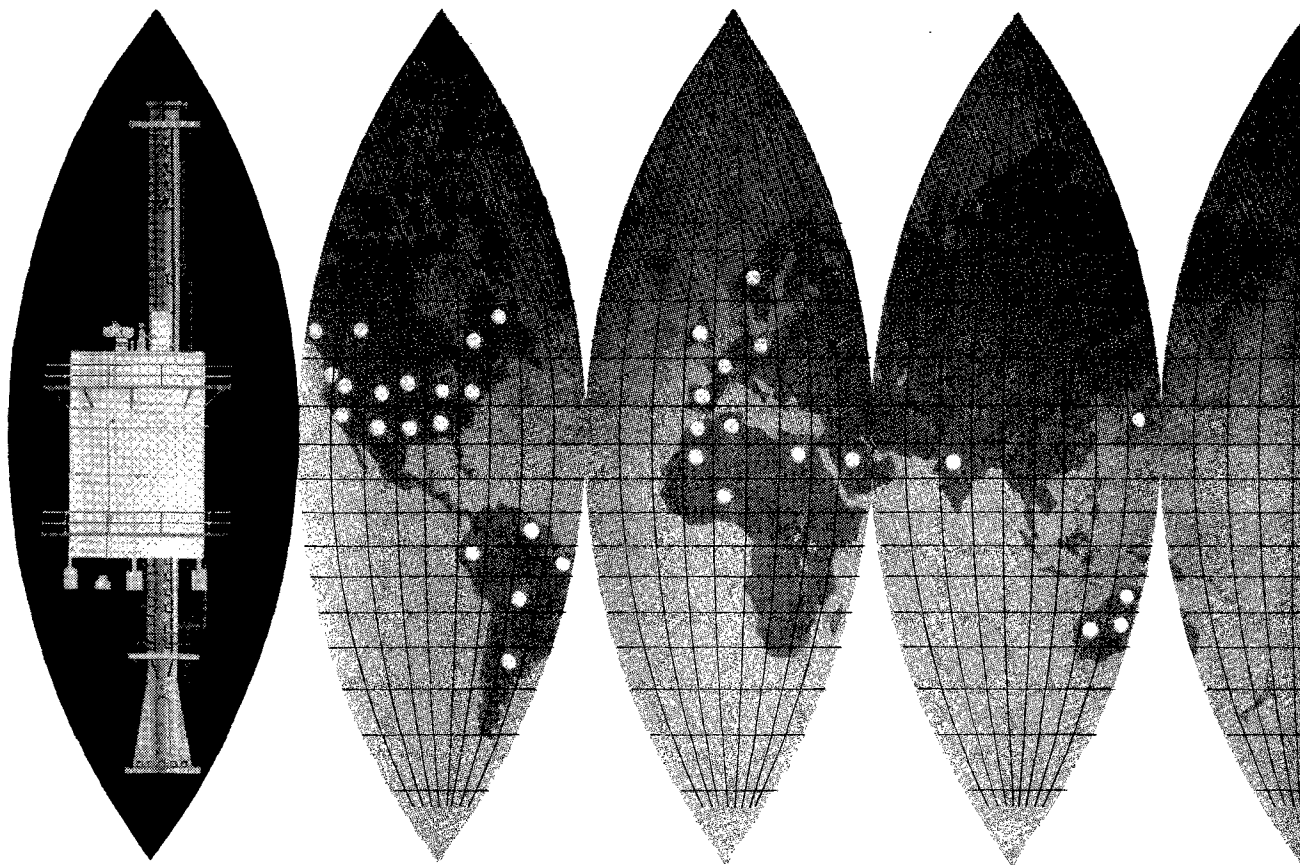

all over the world
with **Blaw-Knox**
plants for fat and oil processing

A few of the countries where Blaw-Knox processing plants for vegetable and animal oils and fats have been installed:

Australia	Egypt	Holland	Japan
Canada	England	Israel	Mexico
Ceylon	France	Italy	United States
Denmark			

Throughout the world, you will find such Blaw-Knox-built facilities. These automatically controlled, continuous operations are noted for high yields, uniformity and quality of products, profitable investment, minimum maintenance and low operating costs. We welcome the opportunity to make recommendations of units to meet your requirements for producing desirable end products from a variety of raw materials.

Blaw-Knox engineers have the experience and technical knowledge for designing, building and placing in operation plants for the solvent extraction of oils, oil refining and deodorization, oil and fat hydrogenation, fat splitting, fatty acid distillation, fatty acid fractionation, fatty acid separation, and fatty alcohol manufacture.

BLAW-KNOX COMPANY

Chemical Plants Division

Chicago 1, Illinois

Pittsburgh 22, Pennsylvania

